

Andhra Pradesh State Council of Higher Education

Question Paper Name :	Electrical Engineering EE 29th Sep 2020 Shift 2
Subject Name :	Electrical Engineering (EE)
Creation Date :	2020-09-29 19:09:55
Duration :	120
Total Marks :	120
Display Marks:	No
Share Answer Key With Delivery Engine :	Yes
Actual Answer Key :	Yes

Electrical Engineering (EE)

Group Number :	1
Group Id :	29996535
Group Maximum Duration :	0
Group Minimum Duration :	120
Show Attended Group? :	No
Edit Attended Group? :	No
Break time :	0
Group Marks :	120
Is this Group for Examiner? :	No
Revisit allowed for group Instructions? :	Yes
Maximum Instruction Time :	0
Minimum Instruction Time :	0

Electrical Engineering (EE)

Section Id :	29996535
Section Number :	1
Mandatory or Optional :	Mandatory
Number of Questions :	120
Section Marks :	120
Display Number Panel :	Yes
Group All Questions :	Yes
Mark As Answered Required? :	Yes
Sub-Section Number :	1
Sub-Section Id :	29996535
Question Shuffling Allowed :	Yes

Question Number : 1 Question Id : 2999654081 Question Type : MCQ Display Question Number : Yes Is Question Mandatory : No Single Line Question Option : No Option Orientation : Vertical

The system $2x + y + z = 0, y - z = 0, x + y = 0$ has _____.

Options :

1. unique solution
2. no solution
3. infinite number of solutions
4. exactly three solutions

Question Number : 2 Question Id : 2999654082 Question Type : MCQ Display Question Number : Yes Is Question Mandatory : No Single Line Question Option : No Option Orientation : Vertical

Let $f(x) = \int_0^x \frac{t^6}{1+t^4} dt, \forall x \geq 0$. Then the value of $f'(2)$ is

Options :

1. $67/17$
2. 0
3. $-17/20$
4. $35/27$

Question Number : 3 Question Id : 2999654083 Question Type : MCQ Display Question Number : Yes Is Question Mandatory : No Single Line Question Option : No Option Orientation : Vertical

A solution of the differential equation $D^3 + D^2 + 4D + 4 = 0$ is

Options :

1. $y = c_1 e^{-x} + c_2 \cos 2x + c_3 \sin 2x$
2. $y = c_1 e^x + c_2 \cos 2x + c_3 \sin 2x$
3. $y = c_1 e^{2x} + c_2 \cos 2x + c_3 \sin 2x$

4. $y = c_1 e^{-x} + c_2 \cos x + c_3 \sin x$

Question Number : 4 Question Id : 2999654084 Question Type : MCQ Display Question Number : Yes Is Question Mandatory : No Single Line Question Option : No Option Orientation : Vertical

The wave propagation $u(x, t)$ of the one dimensional wave equation

$$\frac{\partial^2 u}{\partial t^2} = 4 \frac{\partial^2 u}{\partial x^2}, \quad -\infty < x < \infty, \quad t > 0,$$

$$u(x, 0) = f(x), \quad \frac{\partial u}{\partial t}(x, 0) = 0 \quad \text{is given by}$$

Options :

1. $\frac{1}{2} [f(x + 2t) + f(x - 2t)]$

2. $\frac{1}{2} [f(x + 4t) + f(x - 2t)]$

3. $\frac{1}{2} [f(x + 4t) + f(x + 2t)]$

4. $\frac{1}{2} [f(x + 2t) + f(x - 4t)]$

Question Number : 5 Question Id : 2999654085 Question Type : MCQ Display Question Number : Yes Is Question Mandatory : No Single Line Question Option : No Option Orientation : Vertical

Let C be the closed curve $C: |z - 1| = \frac{1}{2}$. Then the value of the integral $\oint_C \frac{z^3 + 2z + 1}{z} dz$

is

Options :

1. $-6\pi i$

2. $4\pi i$

3. 0

4. $2\pi i$



Question Number : 6 Question Id : 2999654086 Question Type : MCQ Display Question Number : Yes Is

Question Mandatory : No Single Line Question Option : No Option Orientation : Vertical

Which one of the complex variable function is analytic and has real part $2x(1 - y)$?

Options :

1. $f(z) = z^2 + 2iz + c$

2. $f(z) = iz^2 + 2z + c$

3. $f(z) = z^2 + 2z + c$

4. $f(z) = z^2 + z + c$

Question Number : 7 Question Id : 2999654087 Question Type : MCQ Display Question Number : Yes Is Question Mandatory : No Single Line Question Option : No Option Orientation : Vertical

The mean of 200 items was 50. Later on it was discovered that two items were misread as 92 and 8 instead as 192 and 88. What is the correct mean?

Options :

1. 53.6

2. 55

3. 54

4. 56.3

Question Number : 8 Question Id : 2999654088 Question Type : MCQ Display Question Number : Yes Is Question Mandatory : No Single Line Question Option : No Option Orientation : Vertical

A continuous random variable X has the probability density function as

$$f(x) = \begin{cases} a - 2x, & 0 \leq x \leq 1 \\ 0, & \text{otherwise} \end{cases}$$

If the mean of this distribution is $1/3$, then the value of a is

Options :

1. 1

2.

3. $\frac{1}{2}$

4. $\frac{1}{3}$

Question Number : 9 Question Id : 2999654089 Question Type : MCQ Display Question Number : Yes Is Question Mandatory : No Single Line Question Option : No Option Orientation : Vertical

The first approximation to the solution to the system of equations

$$\begin{aligned}8x - 3y + 2z &= 20, \\4x + 11y - z &= 33, \\6x + 3y + 12z &= 36\end{aligned}$$

by using the Gauss –Jacobi method with the initial approximation $(0, 0, 0)$ is

Options :

1. $(3, 2.5, 2.5)$

2. $(8.2, 12, 10)$

3. $(2.5, 3, 3)$

4. $(12, 8.2, 10)$

Question Number : 10 Question Id : 2999654090 Question Type : MCQ Display Question Number : Yes Is Question Mandatory : No Single Line Question Option : No Option Orientation : Vertical

If $\frac{dy}{dx} = x + y$ and $y(0) = 1$, then by Euler's method $y(0.2) =$

Options :

1. 1.20

2. 1.25

3. 1.4

4. 1.00

Question Number : 11 Question Id : 2999654091 Question Type : MCQ Display Question Number : Yes Is Question Mandatory : No Single Line Question Option : No Option Orientation : Vertical

A series RLC circuit with $R = 4\Omega$, $L = 2\text{H}$ and $C = 0.5\text{F}$ is excited with a step input.

The current response is _____.

Options :

1. critically damped

2. over damped

3. damped sinusoid

4. a constant

Question Number : 12 Question Id : 2999654092 Question Type : MCQ Display Question Number : Yes Is Question Mandatory : No Single Line Question Option : No Option Orientation : Vertical

In the following figure, C_1 and C_2 are ideal capacitors. C_1 has been charged to 12 V before the ideal switch S is closed at $t = 0$. The current $i(t)$ for all 't' is _____.

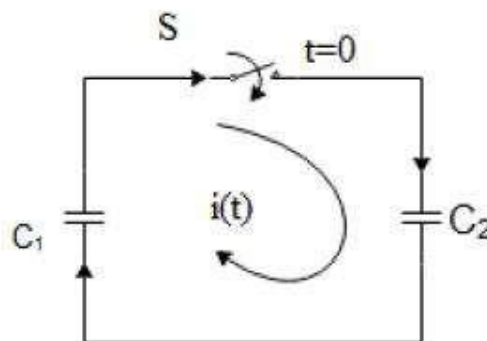

Options :

1. zero

2. a step function

3. an exponentially decaying function
4. an impulse function

Question Number : 13 Question Id : 2999654093 Question Type : MCQ Display Question Number : Yes Is Question Mandatory : No Single Line Question Option : No Option Orientation : Vertical

The transmission parameters of a two-port network are $\begin{bmatrix} A & B \\ C & D \end{bmatrix} = \begin{bmatrix} 2 & 1 \\ 1 & 2 \end{bmatrix}$.

If a 1Ω resistor is connected in series with one of the input leads. Then the transmission parameters of the overall two-port network will be

Options :

1. $\begin{bmatrix} 1 & 3 \\ 3 & 2 \end{bmatrix}$

2. $\begin{bmatrix} 3 & 3 \\ 1 & 2 \end{bmatrix}$

3. $\begin{bmatrix} 1 & 2 \\ 3 & 3 \end{bmatrix}$

4. $\begin{bmatrix} 2 & 3 \\ 1 & 3 \end{bmatrix}$

Question Number : 14 Question Id : 2999654094 Question Type : MCQ Display Question Number : Yes Is Question Mandatory : No Single Line Question Option : No Option Orientation : Vertical

What is the value of total electric flux coming out of a closed surface?

Options :

1. Zero

2. Equal to volume charge density

3. Equal to the total charge enclosed by the surface.

4. Equal to the surface charge density

Question Number : 15 Question Id : 2999654095 Question Type : MCQ Display Question Number : Yes Is Question Mandatory : No Single Line Question Option : No Option Orientation : Vertical

The circuit shown in the figure, is a _____.

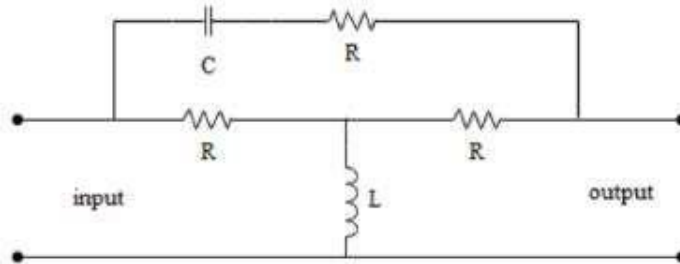

Options :

1. low pass filter
2. high pass filter
3. band pass filter
4. band stop filter

Question Number : 16 Question Id : 2999654096 Question Type : MCQ Display Question Number : Yes Is Question Mandatory : No Single Line Question Option : No Option Orientation : Vertical

The network given below is connected in series with 100Ω resistance. The total impedance of the circuit is given by

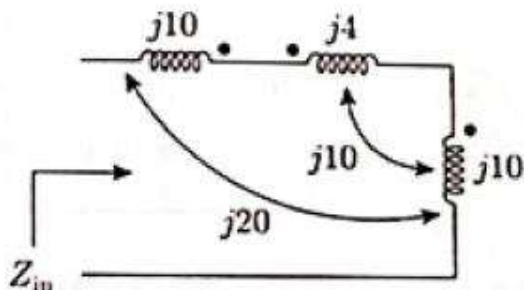

Options :

1. $100+j14 \Omega$
2. $100+j24 \Omega$
3. $100+j4 \Omega$
4. $100+j54 \Omega$

Question Number : 17 Question Id : 2999654097 Question Type : MCQ Display Question Number : Yes Is Question Mandatory : No Single Line Question Option : No Option Orientation : Vertical

The time constant of the given circuit is _____.

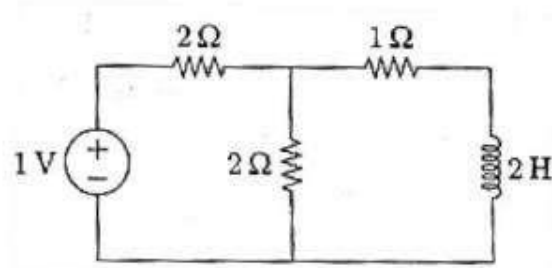

Options :

1. 2 s
2. 0.75 s
3. 3 s
4. 1 s

Question Number : 18 Question Id : 2999654098 Question Type : MCQ Display Question Number : Yes Is Question Mandatory : No Single Line Question Option : No Option Orientation : Vertical

Figure given below shows the waveform of the current passing through an inductor of resistance $2\ \Omega$ and inductance $2\ \text{H}$. The heat energy dissipated by the inductor in the first four seconds is _____.

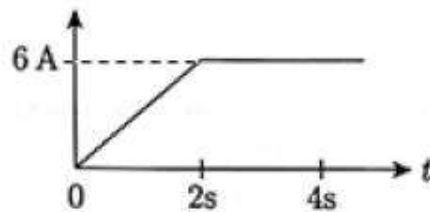

Options :

1. 96 J
2. 192J
3. 132 J
4. 228 J

Question Number : 19 Question Id : 2999654099 Question Type : MCQ Display Question Number : Yes Is Question Mandatory : No Single Line Question Option : No Option Orientation : Vertical

The rms value of the resultant current in a wire which carries a DC current of $10\ \text{A}$, a sinusoidal alternating current of peak value $20\ \text{A}$ at $50\ \text{Hz}$ and another sinusoidal alternating current of peak value $10\ \text{A}$ at $150\ \text{Hz}$ is _____.

Options :

1. 20 A
2. 25.81 A
3. 15.8 A
4. 18.71 A

Question Number : 20 Question Id : 2999654100 Question Type : MCQ Display Question Number : Yes Is

Question Mandatory : No Single Line Question Option : No Option Orientation : Vertical

The input voltage to a load is $v_i = 100\sin 314t$ volts and the current drawn is

$$i = 10 \sin\left(314t - \frac{\pi}{3}\right) + 5 \sin\left(3 * 314t + \frac{\pi}{4}\right) + 2\sin\left(5 * 314t - \frac{\pi}{6}\right)A. \quad \text{Then}$$

the load power factor is _____.

Options :

1. 0.5
2. 0.44
3. 0.32
4. 0.71

Question Number : 21 Question Id : 2999654101 Question Type : MCQ Display Question Number : Yes Is Question Mandatory : No Single Line Question Option : No Option Orientation : Vertical

Which one is true for the circuit shown below?

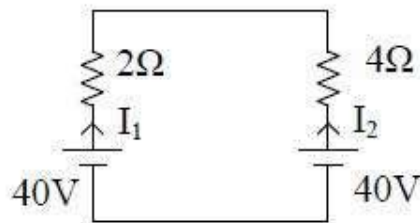

Options :

1. No current in the loop
2. $I_2 > I_1$
3. $I_1 = -2I_2$
4. $I_1 = 2I_2$

Question Number : 22 Question Id : 2999654102 Question Type : MCQ Display Question Number : Yes Is Question Mandatory : No Single Line Question Option : No Option Orientation : Vertical

If I_1 is 6A in the Fig.(a), what will be the current I_2 in the Fig.(b)?

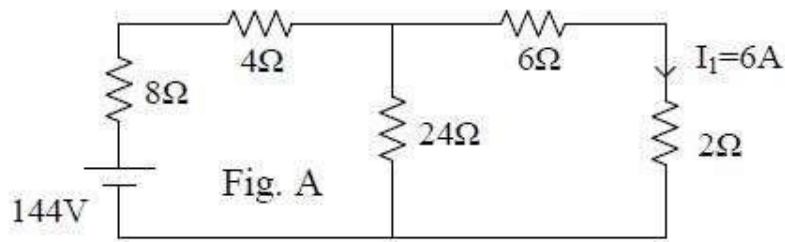

Fig. (a)

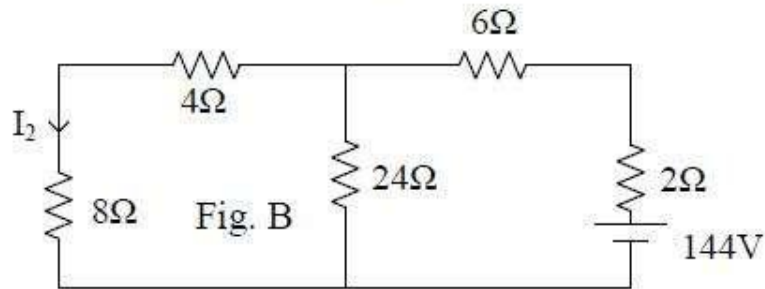

Fig. (b)

Options :

1. 6 A
2. 3 A
3. -3 A
4. < 3A

Question Number : 23 Question Id : 2999654103 Question Type : MCQ Display Question Number : Yes Is Question Mandatory : No Single Line Question Option : No Option Orientation : Vertical

Power consumed by resistances connected in delta is _____ by the same resistances connected in star.

Options :

1. Same
2. Less
3. 9 times more

3 times more

4.

Question Number : 24 Question Id : 2999654104 Question Type : MCQ Display Question Number : Yes Is Question Mandatory : No Single Line Question Option : No Option Orientation : Vertical

A three phase motor connected with a 400 V balanced system consumes 1732 watt at a power factor of 0.5. The line current is _____.

Options :

1. 10 amp

2. 25 amp

3. 8.66 amp

4. 5 amp

Question Number : 25 Question Id : 2999654105 Question Type : MCQ Display Question Number : Yes Is Question Mandatory : No Single Line Question Option : No Option Orientation : Vertical

The voltage and current in a circuit are given by

$$v = 10 \sin (wt - \pi/6)$$

$$i = 10 \sin (wt + \pi/6). \text{ The power consumed by the circuit is _____.}$$

Options :

1. 100 watts

2. 50 watts

3. 86.6 watts

4. 25 watts



Question Number : 26 Question Id : 2999654106 Question Type : MCQ Display Question Number : Yes Is Question Mandatory : No Single Line Question Option : No Option Orientation : Vertical

Let $x(t)$ be a periodic signal with time period T . Let $y(t) = x(t-t_0) + x(t+t_0)$ for some t_0 . The Fourier series coefficients of $y(t)$ are denoted by b_k . If $b_k = 0$ for all odd k , then t_0 can be equal to _____.

Options :

1. $T/8$

2. $T/4$

3. $T/2$

4. $2T$

Question Number : 27 Question Id : 2999654107 Question Type : MCQ Display Question Number : Yes Is Question Mandatory : No Single Line Question Option : No Option Orientation : Vertical

Consider the function $F(s) = \frac{5}{s(s^2 + 3s + 2)}$ where $F(s)$ is the Laplace transform of

the function $f(t)$. The initial value of $f(t)$ is equal to _____.

Options :

1. 5

2. $5/2$

3. $5/3$

4. 0

Question Number : 28 Question Id : 2999654108 Question Type : MCQ Display Question Number : Yes Is Question Mandatory : No Single Line Question Option : No Option Orientation : Vertical

The system represented by the input-output relationship: $y(t) = \int_{-\infty}^{5t} x(\tau) d\tau$, $t > 0$

is _____.

Options :

1. linear and causal
2. linear but not causal
3. causal but not linear
4. neither linear nor causal

Question Number : 29 Question Id : 2999654109 Question Type : MCQ Display Question Number : Yes Is Question Mandatory : No Single Line Question Option : No Option Orientation : Vertical

The Laplace Transform of a signal $y(t) = 6 u(t-1) u(4-t)$ is _____.

Options :

1. $\frac{6}{s} [e^{-s} - e^{-4s}]$
2. $\frac{6}{s} [e^{-s} + e^{4s}]$
3. $\frac{6}{s} [-e^{-s} + e^{-4s}]$
4. $-\frac{6}{s} e^{-5s}$

Question Number : 30 Question Id : 2999654110 Question Type : MCQ Display Question Number : Yes Is Question Mandatory : No Single Line Question Option : No Option Orientation : Vertical

Discrete time signal $x(k) = (-1)^k$, is periodic with fundamental period _____.

Options :

1. 1
2. 2

3. 3

4. 4

Question Number : 31 Question Id : 2999654111 Question Type : MCQ Display Question Number : Yes Is Question Mandatory : No Single Line Question Option : No Option Orientation : Vertical

The discrete time system given by $h_2[n] = -\beta^n u[-n-1]$ where $|\beta| > 1$ is _____.

Options :

1. Causal & stable system
2. Anti Causal & unstable system
3. Anti Causal & stable system
4. Causal & unstable system

Question Number : 32 Question Id : 2999654112 Question Type : MCQ Display Question Number : Yes Is Question Mandatory : No Single Line Question Option : No Option Orientation : Vertical

Determine the inverse z-transform of $X(z) = \frac{1}{1 - 1.5z^{-1} + 0.5z^{-2}}$

where ROC: $|Z| > 1$

Options :

1. $x[n] = \left\{ \underset{\uparrow}{1}, \underset{\uparrow}{\frac{2}{3}}, \underset{\uparrow}{\frac{7}{4}}, \dots \right\}$

2. $x[n] = \left\{ \underset{\uparrow}{1}, \underset{\uparrow}{\frac{2}{3}}, \underset{\uparrow}{\frac{7}{4}}, \dots \right\}$

3.
$$x[n] = \left\{ 1, \frac{2}{3}, -\frac{7}{4}, \dots \right\}$$

4.
$$x[n] = \left\{ 1, \frac{3}{2}, \frac{7}{4}, \dots \right\}$$

Question Number : 33 Question Id : 2999654113 Question Type : MCQ Display Question Number : Yes Is Question Mandatory : No Single Line Question Option : No Option Orientation : Vertical

What is discrete time Fourier transform of the sequence given by $x[n] = \alpha^n u[n], \alpha < 1$?

Options :

1.
$$\frac{1}{1 - \alpha e^{-j\omega}}$$

2.
$$\frac{1}{1 - \alpha e^{j\omega}}$$

3.
$$\frac{\alpha}{1 - \alpha e^{-j\omega}}$$

4.
$$\frac{\alpha}{1 + \alpha e^{+j\omega}}$$

Question Number : 34 Question Id : 2999654114 Question Type : MCQ Display Question Number : Yes Is Question Mandatory : No Single Line Question Option : No Option Orientation : Vertical

Determine response of LTI system $h[n] = \{1, 2, 1, -1\}$, if input signal is

$$x(n) = \{1, 2, 3, 1\}$$

Options :

1. $y[n] = \{1, 4, 8, 8, 3, -2, -1\}$

2. $y[n] = \{1, 4, 8, 8, 3, -2, -1\}$

3. $y[n] = \{1, 4, 8, 8, 3, -2, -1\}$

4. $y[n] = \{1, 4, 8, 8, 3, -2, -1\}$

Question Number : 35 Question Id : 2999654115 Question Type : MCQ Display Question Number : Yes Is Question Mandatory : No Single Line Question Option : No Option Orientation : Vertical

Find out Nyquist rate of following signal:

$$x(t) = 3 \sin 10\pi t + 100 \sin 400\pi t - 9 \cos 110\pi t$$

Options :

1. More than 5 Hz

2. More than 200 Hz

3. More than 110 Hz

4. Less than 110 Hz

Question Number : 36 Question Id : 2999654116 Question Type : MCQ Display Question Number : Yes Is Question Mandatory : No Single Line Question Option : No Option Orientation : Vertical

A synchronous generator is feeding a zero-power factor (lagging) load at rated current, the armature reaction is _____.

Options :

1. Magnetizing

2. Demagnetizing
3. Cross magnetizing
4. Ineffective

Question Number : 37 Question Id : 2999654117 Question Type : MCQ Display Question Number : Yes Is Question Mandatory : No Single Line Question Option : No Option Orientation : Vertical

When the Transformer winding suffers a short circuit, adjoining turns of the same winding experiences _____.

Options :

1. an attractive force
2. a repulsive force
3. no force
4. attractive or repulsive depending upon current direction

Question Number : 38 Question Id : 2999654118 Question Type : MCQ Display Question Number : Yes Is Question Mandatory : No Single Line Question Option : No Option Orientation : Vertical

A 400 V, 15 kW, 4-pole, 50 Hz, Y-connected induction motor has full load slip of 4%. The output torque of the machine at full load is _____.

Options :

1. 1.66 Nm
2. 95.50 Nm
3. 99.47 Nm
4. 624.73 Nm

Question Number : 39 Question Id : 2999654119 Question Type : MCQ Display Question Number : Yes Is Question Mandatory : No Single Line Question Option : No Option Orientation : Vertical

In a DC motor running at 2000 rpm, the hysteresis and eddy current losses are 500 W and 200 W respectively. If the flux remains constant, calculate the speed at which the total iron losses are halved.

Options :

1. 2000 rpm
2. 1140 rpm
3. 1248 rpm
4. 1250 rpm

Question Number : 40 Question Id : 2999654120 Question Type : MCQ Display Question Number : Yes Is Question Mandatory : No Single Line Question Option : No Option Orientation : Vertical

The distribution factor for a 36-slot stator with three-phase, 8 pole winding, having 120° phase spread, is _____.

Options :

1. 0.707
2. 0.844
3. 0.9
4. 0.5

Question Number : 41 Question Id : 2999654121 Question Type : MCQ Display Question Number : Yes Is Question Mandatory : No Single Line Question Option : No Option Orientation : Vertical

A 2200/220 V transformer draws a no load primary current of 0.6 A and absorbs 400 W. Find the magnetizing current.

Options :

1. 0.8 A
2. 0.7 A
3. 0.572 A
4. 0.9 A

Question Number : 42 Question Id : 2999654122 Question Type : MCQ Display Question Number : Yes Is Question Mandatory : No Single Line Question Option : No Option Orientation : Vertical

If applied voltage of a certain transformer is increased by 50% and frequency is reduced to 50% (assuming magnetic circuits remain unsaturated) maximum core flux density will

Options :

1. change to 3 times its original value
2. change to 1.5 times its original value
3. change to 0.5 times its original value
4. remains same as before

Question Number : 43 Question Id : 2999654123 Question Type : MCQ Display Question Number : Yes Is Question Mandatory : No Single Line Question Option : No Option Orientation : Vertical

The E_b/V ratio of a DC motor is an indication of its _____.

Options :

1. efficiency
2. speed regulation
3. starting torque

4. running torque

Question Number : 44 Question Id : 2999654124 Question Type : MCQ Display Question Number : Yes Is Question Mandatory : No Single Line Question Option : No Option Orientation : Vertical

A 3- ϕ induction motor has 4-pole star connected stator winding and runs on 220 V, 50 Hz supply. The rotor resistance is 0.1Ω and reactance 0.9Ω . The stator to rotor turns ratio is 1.75 and the full load slip is 5%. The maximum torque is _____.

Options :

1. 56 Nm
2. 184.8 Nm
3. 61.56 Nm
4. 99.5 Nm

Question Number : 45 Question Id : 2999654125 Question Type : MCQ Display Question Number : Yes Is Question Mandatory : No Single Line Question Option : No Option Orientation : Vertical

The full load voltage regulation of an alternator is 6% at 0.8 pf lagging and at rated speed of 1200 rpm. Its full load regulation at 0.8 pf lagging and at 1100 rpm would be (assuming negligible armature resistance)

Options :

1. less than 6%
2. more than 6%
3. 6%
4. 5.5%

Question Number : 46 Question Id : 2999654126 Question Type : MCQ Display Question Number : Yes Is Question Mandatory : No Single Line Question Option : No Option Orientation : Vertical

A Δ -Y connected three phase core type transformer with 1:1 winding is on no-load and supply to one of the terminal is failed. Assuming magnetic circuit symmetry, voltages on secondary side will be _____. (Take secondary rated line voltage is 400 V)

Options :

1. 230,230,115
2. 230,115,115
3. 345,115,115
4. 345,0,345

Question Number : 47 Question Id : 2999654127 Question Type : MCQ Display Question Number : Yes Is Question Mandatory : No Single Line Question Option : No Option Orientation : Vertical

A three phase star connected induction motor is connected to 400 V, 50 Hz AC supply. If the stator to rotor turn ratio is 2, the standstill rotor induced emf per phase is _____.

Options :

1. 115.5 V
2. 231 V
3. 346.5 V
4. 200 V

Question Number : 48 Question Id : 2999654128 Question Type : MCQ Display Question Number : Yes Is Question Mandatory : No Single Line Question Option : No Option Orientation : Vertical

Wattmeter readings during OC test (at rated voltage) and SC test (at rated current) on a 10 kVA single phase transformer are respectively 64 W and 100 W. Maximum efficiency will occur when the transformer is loaded to _____.

Options :

1. 8.0 kVA at upf
2. 6.4 kVA at 0.8 lagging pf
3. 12.5 kVA at upf
4. 8.0 kVA at 0.8 leading pf

Question Number : 49 Question Id : 2999654129 Question Type : MCQ Display Question Number : Yes Is Question Mandatory : No Single Line Question Option : No Option Orientation : Vertical

How many number of commutator segments are required, if a DC machine uses 72 number of coils?

Options :

1. 36
2. 144
3. 72
4. 18

Question Number : 50 Question Id : 2999654130 Question Type : MCQ Display Question Number : Yes Is Question Mandatory : No Single Line Question Option : No Option Orientation : Vertical

In the circle diagram of an induction motor, diameter of the circle represents _____.

Options :

1. slip
2. running torque

3. line voltage
4. rotor current

Question Number : 51 Question Id : 2999654131 Question Type : MCQ Display Question Number : Yes Is Question Mandatory : No Single Line Question Option : No Option Orientation : Vertical

The presence of earth in case of overhead lines _____.

Options :

1. increases the capacitance
2. decreases the capacitance
3. increases the inductance
4. decreases the inductance

Question Number : 52 Question Id : 2999654132 Question Type : MCQ Display Question Number : Yes Is Question Mandatory : No Single Line Question Option : No Option Orientation : Vertical

The angle δ in the swing equation of a synchronous generator is the

Options :

1. angle between stator voltage and current.
2. angular displacement of the rotor with respect to the stator.
3. angular displacement of the stator mmf with respect to a synchronously rotating axis.
4. angular displacement of the rotor with respect to a stationary axis.

Question Number : 53 Question Id : 2999654133 Question Type : MCQ Display Question Number : Yes Is Question Mandatory : No Single Line Question Option : No Option Orientation : Vertical

The line impedance of a three phase transmission line is given by $Z = (10+j5) \Omega$. How much is the transmission loss, if the power delivered by the transmission line is 100 MVA at 132 kV?

Options :

1. 10 MW
2. 5.74 MW
3. 11.5 MW
4. 1 MW

Question Number : 54 Question Id : 2999654134 Question Type : MCQ Display Question Number : Yes Is Question Mandatory : No Single Line Question Option : No Option Orientation : Vertical

A 3-phase load of 200 kVA is delivered at 11 kV over a short transmission line of $R = 10 \Omega$ and $X = 0.5 \Omega$. If the load pf is 0.8 lag, the sending end power is _____.

Options :

1. 161.1 kW
2. 200 kW
3. 100 kW
4. 165.3 kW

Question Number : 55 Question Id : 2999654135 Question Type : MCQ Display Question Number : Yes Is Question Mandatory : No Single Line Question Option : No Option Orientation : Vertical

A system has 200 buses of which 20 buses are generator buses and the rest are load buses. The size of Jacobian matrix in Newton-Rapson load flow method is _____.

Options :

1. 376×376

2. 378×378

3. 380×380

4. 379×379

Question Number : 56 Question Id : 2999654136 Question Type : MCQ Display Question Number : Yes Is Question Mandatory : No Single Line Question Option : No Option Orientation : Vertical

A uniform DC radial distribution system of 500 m length has a resistance of 0.2 ohm/km. If it is loaded at 3A/m, its maximum voltage drop is _____.

Options :

1. 100 V

2. 150 V

3. Zero

4. 300 V

Question Number : 57 Question Id : 2999654137 Question Type : MCQ Display Question Number : Yes Is Question Mandatory : No Single Line Question Option : No Option Orientation : Vertical

For a 100 MVA, 11 kV, 50 Hz, 4-pole turbo generator with 800 MJ stored energy in the rotor at synchronous speed, the inertia constant H is _____.

Options :

1. 2.0 MJ/MVA

2. 40 MJ/MVA

3. 6.0 MJ/MVA

4. 8.0 MJ/MVA

Question Number : 58 Question Id : 2999654138 Question Type : MCQ Display Question Number : Yes Is Question Mandatory : No Single Line Question Option : No Option Orientation : Vertical

A three phase transmission line is 400 km long. The voltage at the sending end is 220 kV. If line parameter 'A' is 0.90, then the receiving end voltage at no load is _____.

Options :

1. 198 kV
2. 244.4 kV
3. 220 kV
4. 230 kV

Question Number : 59 Question Id : 2999654139 Question Type : MCQ Display Question Number : Yes Is Question Mandatory : No Single Line Question Option : No Option Orientation : Vertical

In Gauss-Seidel load flow method, α (Alpha) is used _____.

Options :

1. to enhance rate of convergence
2. to enhance the stability limit
3. to decrease the voltage values of the bus bar
4. to count the iteration number

Question Number : 60 Question Id : 2999654140 Question Type : MCQ Display Question Number : Yes Is Question Mandatory : No Single Line Question Option : No Option Orientation : Vertical

A Mho relay is a _____.

Options :

1. voltage restrained directional relay

2. voltage controlled over current relay
3. directional restrained over current relay
4. directional restrained over voltage relay

Question Number : 61 Question Id : 2999654141 Question Type : MCQ Display Question Number : Yes Is Question Mandatory : No Single Line Question Option : No Option Orientation : Vertical

In a thermal power plant, the feed water coming to the economizer is heated using

Options :

1. HP Steam
2. LP Steam
3. direct heat in the furnace
4. flue gases

Question Number : 62 Question Id : 2999654142 Question Type : MCQ Display Question Number : Yes Is Question Mandatory : No Single Line Question Option : No Option Orientation : Vertical

Number of forward paths in the given signal flow graph is _____.

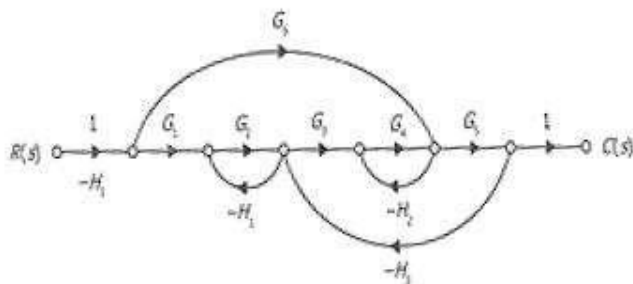

Options :

1. 1
2. 2

3. 3

4. 4

Question Number : 63 Question Id : 2999654143 Question Type : MCQ Display Question Number : Yes Is Question Mandatory : No Single Line Question Option : No Option Orientation : Vertical

The transmission line distance protection relay having the property of being inherently directional is

Options :

1. Impedance relay

2. Reactance relay

3. OHM relay

4. Mho relay

Question Number : 64 Question Id : 2999654144 Question Type : MCQ Display Question Number : Yes Is Question Mandatory : No Single Line Question Option : No Option Orientation : Vertical

Critical clearing time of a fault in power system is related to _____.

Options :

1. Reactive power limit

2. Short circuit limit

3. Steady state stability limit

4. Transient stability limit

Question Number : 65 Question Id : 2999654145 Question Type : MCQ Display Question Number : Yes Is Question Mandatory : No Single Line Question Option : No Option Orientation : Vertical

Which one of the following cannot be determined using equal area criterion?

Options :

1. Critical clearing angle
2. Critical clearing time
3. Transient stability limit
4. Both critical clearing angle and critical clearing time

Question Number : 66 Question Id : 2999654146 Question Type : MCQ Display Question Number : Yes Is Question Mandatory : No Single Line Question Option : No Option Orientation : Vertical

The transfer function of the system is described by $\frac{d^2y}{dt^2} + \frac{dy}{dt} = \frac{du}{dt} + 2u$, with u as input and y as output is _____.

Options :

1. $\frac{(s+2)}{(s^2+s)}$
2. $\frac{(s+1)}{(s^2+s)}$
3. $\frac{2}{(s^2+s)}$
4. $\frac{2s}{(s^2+s)}$

Question Number : 67 Question Id : 2999654147 Question Type : MCQ Display Question Number : Yes Is Question Mandatory : No Single Line Question Option : No Option Orientation : Vertical

Three blocks G_1 , G_2 and G_3 are connected in some fashion such that overall transfer function is $\frac{G_1 + G_3(1 + G_1G_2)}{(1 + G_1G_2)}$. Which of the following options is correct to get the given transfer function?

Options :

1. G_1 , G_2 with negative feedback and combination in parallel with G_3
2. G_1 , G_3 with negative feedback and G_2 in parallel
3. G_1 , G_2 in cascade and combination in parallel with G_3
4. G_1 , G_3 in cascade and combination in parallel with G_2

Question Number : 68 Question Id : 2999654148 Question Type : MCQ Display Question Number : Yes Is Question Mandatory : No Single Line Question Option : No Option Orientation : Vertical

If a second order system has poles at $(-1 \pm j)$, then the step response of the system will exhibit a peak value at _____.

Options :

1. 4.5 sec
2. 3.5 sec
3. 3.14 sec
4. 1 sec

Question Number : 69 Question Id : 2999654149 Question Type : MCQ Display Question Number : Yes Is Question Mandatory : No Single Line Question Option : No Option Orientation : Vertical

The settling time of an under damped second order system for 5% tolerance band is 10 s. The peak time is 1s. How many cycles the damped response completes, before the system settles?

Options :

1. 10
2. 17
3. 21
4. 25

Question Number : 70 Question Id : 2999654150 Question Type : MCQ Display Question Number : Yes Is Question Mandatory : No Single Line Question Option : No Option Orientation : Vertical

The step response of a first-order system is as shown in the following figure.

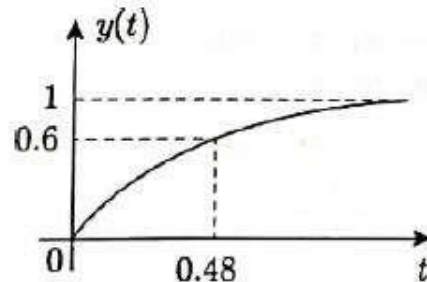

The time constant of the system is _____.

Options :

1. 0.612 s
2. 0.524 s
3. 0.124 s
4. 0.254 s

Question Number : 71 Question Id : 2999654151 Question Type : MCQ Display Question Number : Yes Is Question Mandatory : No Single Line Question Option : No Option Orientation : Vertical

A system has characteristic equation of $s^3 + Ks^2 + 9s + 18 = 0$. The value of K and frequency of sustained oscillations ω_n for the given system are respectively _____,

Options :

1. 4, 5
2. 5, 6
3. 2, 3
4. 3, 2

Question Number : 72 Question Id : 2999654152 Question Type : MCQ Display Question Number : Yes Is Question Mandatory : No Single Line Question Option : No Option Orientation : Vertical

A single input single output feedback system has forward transfer function $G(s)$ and feedback transfer function $H(s)$. It is given that $|G(s)H(s)| < 1$. Select the correct statement from the following.

Options :

1. The system is always stable
2. The system is stable if all zeros of $G(s)H(s)$ are in the left half of the s-plane
3. The system is stable if all poles of $G(s)H(s)$ are in the left half of the s-plane
4. The system is always unstable

Question Number : 73 Question Id : 2999654153 Question Type : MCQ Display Question Number : Yes Is Question Mandatory : No Single Line Question Option : No Option Orientation : Vertical

A system can be described as, $\dot{x} = Ax + Bu$, where $A = \begin{bmatrix} -1 & 2 \\ 0 & 2 \end{bmatrix}$ and $B = \begin{bmatrix} 0 \\ 1 \end{bmatrix}$.

Then choose the correct statement from the following.

Options :

1. The system is stable and controllable

2. The system is stable but uncontrollable
3. The system is unstable and controllable
4. The system is unstable and uncontrollable.

Question Number : 74 Question Id : 2999654154 Question Type : MCQ Display Question Number : Yes Is Question Mandatory : No Single Line Question Option : No Option Orientation : Vertical

What is the transfer function of positive feedback control system? Assume $G(s)$ to be forward path gain and $H(s)$ to be feedback path gain.

Options :

1.
$$\frac{G(s)}{1 - G(s)H(s)}$$

2.
$$\frac{G(s)}{1 - G(s)}$$

3.
$$\frac{G(s)}{1 + G(s)H(s)}$$

4.
$$\frac{G(s)}{1 + G(s)}$$

Question Number : 75 Question Id : 2999654155 Question Type : MCQ Display Question Number : Yes Is Question Mandatory : No Single Line Question Option : No Option Orientation : Vertical

A unity feedback control system has the open loop transfer function $G(s)$. For the system to be stable, find range of K .

$$G(s) = \frac{K(s + 13)}{s(s + 7)(s + 3)}$$

Options :

1. $[0, 70]$

2. [0,80]

3. [0,90]

4. [0,75]

Question Number : 76 Question Id : 2999654156 Question Type : MCQ Display Question Number : Yes Is Question Mandatory : No Single Line Question Option : No Option Orientation : Vertical

Initial slope of Bode magnitude plot gives information about _____.

Options :

1. type of the system
2. order of characteristic equation
3. gain at frequency of 1 rad/sec
4. number of zeros of open loop transfer function

Question Number : 77 Question Id : 2999654157 Question Type : MCQ Display Question Number : Yes Is Question Mandatory : No Single Line Question Option : No Option Orientation : Vertical

Consider a controller with a lead of 35° and gain of 5.65 dB at 2.8 rad/sec. Which of the following options represents the transfer function of the lead compensator?

Options :

1. $\frac{(1 + 0.2s)}{(1 + 0.7s)}$
2. $\frac{0.5(1 + 0.2s)}{(1 + 0.7s)}$
3. $\frac{(1 + 0.69s)}{(1 + 0.19s)}$

$$4. \frac{0.272(1 + 0.69s)}{(1 + 0.19s)}$$

Question Number : 78 Question Id : 2999654158 Question Type : MCQ Display Question Number : Yes Is Question Mandatory : No Single Line Question Option : No Option Orientation : Vertical

The transfer function of a system is defined as the ratio of output to input in _____.

Options :

1. Fourier transform
2. Laplace transform
3. Z-transform
4. Laplace transform and Fourier transform

Question Number : 79 Question Id : 2999654159 Question Type : MCQ Display Question Number : Yes Is Question Mandatory : No Single Line Question Option : No Option Orientation : Vertical

The state variable description of a system is $\dot{x} = \begin{bmatrix} 2 & 0 \\ -2 & 0 \end{bmatrix}x + \begin{bmatrix} 0 \\ -1 \end{bmatrix}u$.

The state transition matrix of the system is _____.

Options :

1. $\begin{bmatrix} e^{2t} & 0 \\ 0 & e^{2t} \end{bmatrix}$
2. $\begin{bmatrix} e^{-2t} & 0 \\ 0 & e^{-2t} \end{bmatrix}$
3. $\begin{bmatrix} \sin 2t & \cos 2t \\ -\cos 2t & \sin 2t \end{bmatrix}$
4. $\begin{bmatrix} \cos 2t & \sin 2t \\ -\sin 2t & \cos 2t \end{bmatrix}$

Question Number : 80 Question Id : 2999654160 Question Type : MCQ Display Question Number : Yes Is

Question Mandatory : No Single Line Question Option : No Option Orientation : Vertical

In a type-1, second-order system, the first undershoot occurs at a time _____.

Options :

1.
$$t_p = \frac{\pi}{\omega_d}$$

2.
$$t_p = \frac{2\pi}{\omega_d}$$

3.
$$t_p = \frac{\pi}{2\omega_d}$$

4.
$$t_p = \frac{\omega_d}{\pi}$$

Question Number : 81 Question Id : 2999654161 Question Type : MCQ Display Question Number : Yes Is Question Mandatory : No Single Line Question Option : No Option Orientation : Vertical

Torque/weight ratio of an instrument indicates _____.

Options :

1. Selectivity

2. Accuracy

3. Fidelity

4. Sensitivity

Question Number : 82 Question Id : 2999654162 Question Type : MCQ Display Question Number : Yes Is Question Mandatory : No Single Line Question Option : No Option Orientation : Vertical

A 0-10 mA PMMC ammeter reads 4 mA in a circuit. Its bottom control spring snaps suddenly. The meter will now read nearly _____.

Options :

1. 10 mA

1.

2. 8 mA

2.

3. 2 mA

3.

4. zero

4.

Question Number : 83 Question Id : 2999654163 Question Type : MCQ Display Question Number : Yes Is Question Mandatory : No Single Line Question Option : No Option Orientation : Vertical

Power consumed by a balanced three-phase three-wire load is measured by the two-wattmeter method. The first wattmeter reads twice that of the second. Then the load impedance angle in radian is _____.

Options :

1. $\frac{\pi}{2}$

1.

2. $\frac{\pi}{8}$

2.

3. $\frac{\pi}{6}$

3.

4. $\frac{\pi}{3}$

4.

Question Number : 84 Question Id : 2999654164 Question Type : MCQ Display Question Number : Yes Is Question Mandatory : No Single Line Question Option : No Option Orientation : Vertical

A thermo-electric ammeter gives a full scale deflection for a current of 50 A.

Calculate the current which causes half scale deflection.

Options :

1. 5 A

1.

2. 25 A

3. 38.47 A

4. 35.36 A

Question Number : 85 Question Id : 2999654165 Question Type : MCQ Display Question Number : Yes Is Question Mandatory : No Single Line Question Option : No Option Orientation : Vertical

The voltage across a $100\text{ k}\Omega$ resistor is to be measured as shown in the circuit below.

The sensitivity of the voltmeter is $2000\ \Omega/\text{V}$. The range of the voltmeter is $0\text{-}80\text{ V}$.

Then the reading of the voltmeter is _____.

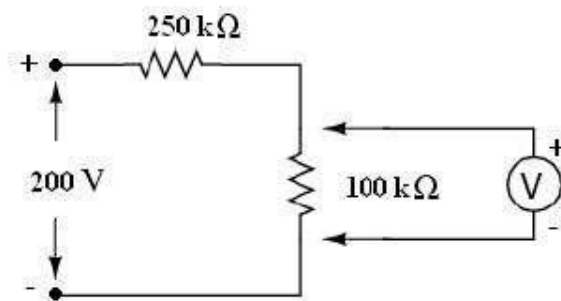

Options :

1. 95.24 V

2. 39.5 V

3. 158.18 V

4. 102.24 V

Question Number : 86 Question Id : 2999654166 Question Type : MCQ Display Question Number : Yes Is Question Mandatory : No Single Line Question Option : No Option Orientation : Vertical

A moving coil instrument gives a full scale deflection of 10 mA when voltage across its terminal is 100 mV . Calculate the value of shunt resistance for a full scale deflection corresponding to 100 A .

Options :

1. 0.01Ω
2. 0.001Ω
3. 0.1Ω
4. 1Ω

Question Number : 87 Question Id : 2999654167 Question Type : MCQ Display Question Number : Yes Is Question Mandatory : No Single Line Question Option : No Option Orientation : Vertical

The instruments that determine the electrical quantity to be measured directly in terms of deflection are called _____.

Options :

1. Absolute instruments
2. Integrating instruments
3. Secondary instruments
4. Recording instruments

Question Number : 88 Question Id : 2999654168 Question Type : MCQ Display Question Number : Yes Is Question Mandatory : No Single Line Question Option : No Option Orientation : Vertical

In a moving coil instrument, the moving coil consists of 300 turns carrying a current of 10 mA wound on a former of dimension $3 \text{ cm} \times 2 \text{ cm}$. If the flux density in the air gap is 0.05 T, the deflecting force is _____.

Options :

1. $0.9 \times 10^{-3} \text{ N}$
2. $0.9 \times 10^{-4} \text{ N}$

3. $4.5N$

4. $4.5 \times 10^{-3} N$

Question Number : 89 Question Id : 2999654169 Question Type : MCQ Display Question Number : Yes Is Question Mandatory : No Single Line Question Option : No Option Orientation : Vertical

The purpose of synchronizing control in a CRO is to _____.

Options :

1. focus the spot on the screen
2. lock the display of signal
3. adjust the amplitude of display
4. control the intensity of the spot

Question Number : 90 Question Id : 2999654170 Question Type : MCQ Display Question Number : Yes Is Question Mandatory : No Single Line Question Option : No Option Orientation : Vertical

With a sweep time 10 msec across the screen, the approximate horizontal saw tooth frequency is _____.

Options :

1. 50 Hz
2. 100 Hz
3. 1 KHz
4. 500 Hz

Question Number : 91 Question Id : 2999654171 Question Type : MCQ Display Question Number : Yes Is Question Mandatory : No Single Line Question Option : No Option Orientation : Vertical

The number of comparisons carried out in a 4-bit flash type A/D converter is _____.

Options :

1. 16
2. 15
3. 4
4. 3

Question Number : 92 Question Id : 2999654172 Question Type : MCQ Display Question Number : Yes Is Question Mandatory : No Single Line Question Option : No Option Orientation : Vertical

The AND function can be realized by using only 'n' number of NOR gates, where 'n' equal to _____.

Options :

1. 2
2. 3
3. 4
4. 5

Question Number : 93 Question Id : 2999654173 Question Type : MCQ Display Question Number : Yes Is Question Mandatory : No Single Line Question Option : No Option Orientation : Vertical

How many flip-flops are required to construct Mod-31 counter?

Options :

1. 4
2. 3
3. 2
4. 5

Question Number : 94 Question Id : 2999654174 Question Type : MCQ Display Question Number : Yes Is Question Mandatory : No Single Line Question Option : No Option Orientation : Vertical

The feedback factor for the circuit shown in the figure is _____.

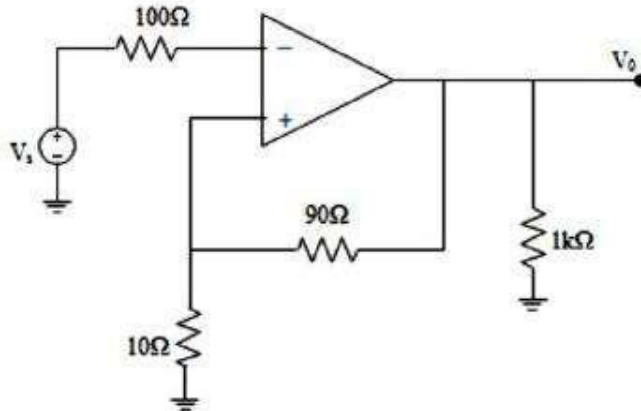

Options :

1. $9/100$
2. $9/10$
3. $1/9$
4. $1/10$

Question Number : 95 Question Id : 2999654175 Question Type : MCQ Display Question Number : Yes Is Question Mandatory : No Single Line Question Option : No Option Orientation : Vertical

The common emitter forward current gain of the transistor circuit shown below is $\beta_F = 100$. The transistor is operating in _____.

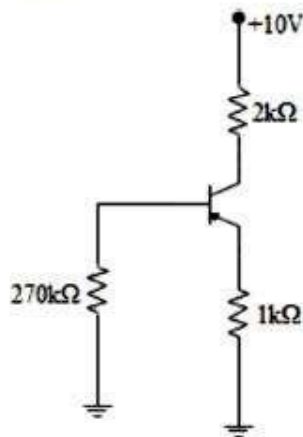

Options :

1. Saturation region
2. Cut-off region
3. Reverse active region
4. Forward active region

Question Number : 96 Question Id : 2999654176 Question Type : MCQ Display Question Number : Yes Is Question Mandatory : No Single Line Question Option : No Option Orientation : Vertical

A JFET is set up as a follower, with $\mu = 200$, $r_d = 100 \text{ k}\Omega$ and source load resistance $R_L = 1 \text{ k}\Omega$. The output resistance R_0 is _____.

Options :

1. 1000Ω
2. 500Ω
3. 333Ω
4. 666Ω

Question Number : 97 Question Id : 2999654177 Question Type : MCQ Display Question Number : Yes Is Question Mandatory : No Single Line Question Option : No Option Orientation : Vertical

The content of the accumulator in an 8085 microprocessor is altered after the execution of the instruction _____.

Options :

1. CMP C
2. CPI 3A
3. ANI 5C

4. ORA A

Question Number : 98 Question Id : 2999654178 Question Type : MCQ Display Question Number : Yes Is Question Mandatory : No Single Line Question Option : No Option Orientation : Vertical

In a transmission line, there is a flow of zero sequence current when

Options :

1. There is an occurrence of an overvoltage on line due to a charged cloud
2. Line to line fault
3. Three phase fault
4. Double line to ground fault

Question Number : 99 Question Id : 2999654179 Question Type : MCQ Display Question Number : Yes Is Question Mandatory : No Single Line Question Option : No Option Orientation : Vertical

A silicon diode shows forward currents of 2 mA and 10 mA when a voltmeter connected across the diode shows 0.6V and 0.7V respectively. The operating temperature of the diode is _____.

Options :

1. 360 K
2. 480K
3. 320K
4. 100K

Question Number : 100 Question Id : 2999654180 Question Type : MCQ Display Question Number : Yes Is Question Mandatory : No Single Line Question Option : No Option Orientation : Vertical

Consider the Darlington pair circuit shown below and h_{fe} of each resistor is 100.

The overall h_{fe} for the pair is _____.

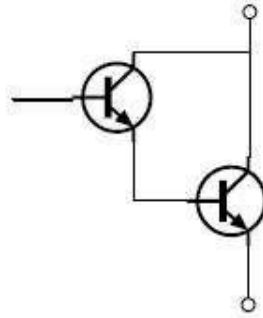

Options :

1. 10000
2. 10001
3. 10100
4. 9900

Question Number : 101 Question Id : 2999654181 Question Type : MCQ Display Question Number : Yes Is Question Mandatory : No Single Line Question Option : No Option Orientation : Vertical

For the given filter circuit, $R_1 = R_2$ and $R_3 = R_4$, it will act as _____.

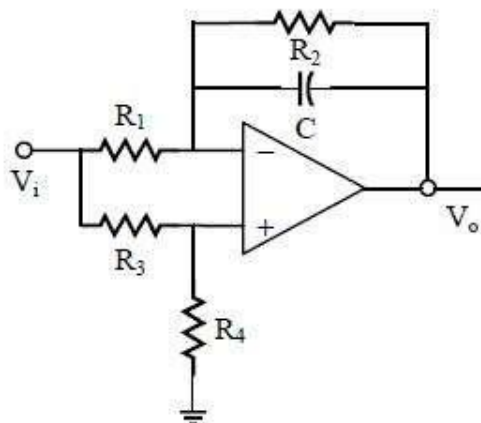

Options :

1. Low pass filter
2. high pass filter

3. band pass filter

4. all pass filter

Question Number : 102 Question Id : 2999654182 Question Type : MCQ Display Question Number : Yes Is Question Mandatory : No Single Line Question Option : No Option Orientation : Vertical

The octal equivalent for the HEX number AB.CD is _____.

Options :

1. 253.314

2. 632.324

3. 632.253

4. 253.632

Question Number : 103 Question Id : 2999654183 Question Type : MCQ Display Question Number : Yes Is Question Mandatory : No Single Line Question Option : No Option Orientation : Vertical

In an 8085 microprocessor, which of the following are direct memory access (DMA) request signals?

Options :

1. INTR and INTA

2. \overline{RD} and \overline{WR}

3. HOLD and HLDA

4. HALT and WRITE

Question Number : 104 Question Id : 2999654184 Question Type : MCQ Display Question Number : Yes Is Question Mandatory : No Single Line Question Option : No Option Orientation : Vertical

Frequency at which gain of Op-Amp is zero dB is called _____.

Options :

1. Gain crossover frequency
2. Unity gain frequency
3. α cut off frequency
4. β cut off frequency

Question Number : 105 Question Id : 2999654185 Question Type : MCQ Display Question Number : Yes Is Question Mandatory : No Single Line Question Option : No Option Orientation : Vertical

Negative feedback in amplifiers _____.

Options :

1. Reduces gain, increases bandwidth, increases distortion
2. Reduces gain, reduces bandwidth, reduces distortion
3. Reduces gain, increases bandwidth, reduces distortion
4. Increases gain, increases bandwidth, reduces distortion

Question Number : 106 Question Id : 2999654186 Question Type : MCQ Display Question Number : Yes Is Question Mandatory : No Single Line Question Option : No Option Orientation : Vertical

In a single-phase semi-converter with resistive load and a firing angle α , each SCR and freewheeling diode conduct for _____ respectively.

Options :

1. $\alpha, 0^\circ$
2. $\pi - \alpha, \alpha$
3. $\pi + \alpha, \alpha$

4. $\pi - \alpha, 0^\circ$

Question Number : 107 Question Id : 2999654187 Question Type : MCQ Display Question Number : Yes Is Question Mandatory : No Single Line Question Option : No Option Orientation : Vertical

A step-up chopper is fed from a 230 V DC source to deliver a load voltage of 690 V. If the non-conduction time of the thyristor is 300 μ s, the required pulse width is _____ μ s.

Options :

1. 200

2. 350

3. 600

4. 150

Question Number : 108 Question Id : 2999654188 Question Type : MCQ Display Question Number : Yes Is Question Mandatory : No Single Line Question Option : No Option Orientation : Vertical

A single-phase voltage controller is connected to a load resistance of 10 Ω and a supply of $200 \sin 314 t$ volts. For a firing angle of 90° , the average thyristor current is _____ amperes.

Options :

1. 10

2. $10/\pi$

3. $5\sqrt{2} / \pi$

4. $5\sqrt{2}$

Question Number : 109 Question Id : 2999654189 Question Type : MCQ Display Question Number : Yes Is Question Mandatory : No Single Line Question Option : No Option Orientation : Vertical

The given figure shows a step-down chopper switched at 1 kHz with a duty ratio $D = 0.5$. The peak-to-peak ripple in the load current is close to _____.

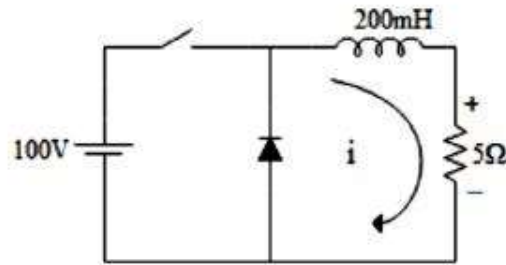

Options :

1. 10 A
2. 0.5 A
3. 0.125 A
4. 0.25 A

Question Number : 110 Question Id : 2999654190 Question Type : MCQ Display Question Number : Yes Is Question Mandatory : No Single Line Question Option : No Option Orientation : Vertical

During the turn-off process of a thyristor, the current flow does not stop at the instant when the current reaches zero, but continues to flow to a peak value in the reverse direction. This is due to _____.

Options :

1. hole storage effect
2. commutation failure
3. presence of reverse voltage across the thyristor
4. protective inductance in series with the thyristor

Question Number : 111 Question Id : 2999654191 Question Type : MCQ Display Question Number : Yes Is Question Mandatory : No Single Line Question Option : No Option Orientation : Vertical

It is preferable to use a high frequency train of pulses for gate triggering of SCR in order to reduce _____.

Options :

1. dv/dt problem
2. di/dt problem
3. the size of the pulse transformer
4. the complexity of the firing circuit

Question Number : 112 Question Id : 2999654192 Question Type : MCQ Display Question Number : Yes Is Question Mandatory : No Single Line Question Option : No Option Orientation : Vertical

A single-phase full-bridge semi-converter with a free-wheeling diode feeds an inductive load. The load resistance is 15Ω with a large inductance providing constant and ripple free DC current. The converter is fed from an ideal 230 V, 50 Hz single phase AC source. For a firing delay angle of 60° , the rms value of diode current is _____.

Options :

1. 5.98 A
2. 4.98 A
3. 6.87 A
4. 10.35 A

Question Number : 113 Question Id : 2999654193 Question Type : MCQ Display Question Number : Yes Is Question Mandatory : No Single Line Question Option : No Option Orientation : Vertical

A semi-controlled rectifier operates in _____.

Options :

1. I – quadrant
2. II – quadrant
3. I and II – quadrants
4. I and IV – quadrants

Question Number : 114 Question Id : 2999654194 Question Type : MCQ Display Question Number : Yes Is Question Mandatory : No Single Line Question Option : No Option Orientation : Vertical

The ripple frequency in a “p” pulse rectifier supplied by “f” Hz supply is given by

Options :

1. $P*f$
2. $2P*f$
3. $(P-1)*f$
4. $2(P-1)*f$

Question Number : 115 Question Id : 2999654195 Question Type : MCQ Display Question Number : Yes Is Question Mandatory : No Single Line Question Option : No Option Orientation : Vertical

In which of the following choppers, does the voltage and current remain negative?

Options :

1. Type-A
2. Type-B
3. Type-C
4. Type-D

Question Number : 116 Question Id : 2999654196 Question Type : MCQ Display Question Number : Yes Is

Question Mandatory : No Single Line Question Option : No Option Orientation : Vertical

Which of the following braking systems on the locomotives is costly?

Options :

1. Vacuum braking on steam locomotives
2. Vacuum braking on diesel locomotives
3. Regenerative braking on electric locomotives
4. All braking systems are equally costly

Question Number : 117 Question Id : 2999654197 Question Type : MCQ Display Question Number : Yes Is Question Mandatory : No Single Line Question Option : No Option Orientation : Vertical

A traction motor consumes maximum energy when it is in the following position of speed-time graph _____.

Options :

1. free running period
2. coasting period
3. Braking period
4. acceleration period

Question Number : 118 Question Id : 2999654198 Question Type : MCQ Display Question Number : Yes Is Question Mandatory : No Single Line Question Option : No Option Orientation : Vertical

The wheels of a train, engine as well as bogies are slightly tapered to _____.

Options :

1. Reduce friction
2. Increase friction

3. Facilitate in taking turns
4. Facilitate braking

Question Number : 119 Question Id : 2999654199 Question Type : MCQ Display Question Number : Yes Is Question Mandatory : No Single Line Question Option : No Option Orientation : Vertical

A series circuit consists of $R = 2.4 \Omega$, $L = 25 \mu\text{H}$, C and a thyristor. For obtaining self-commutation in the circuit the value of C is _____.

Options :

1. $50 \mu\text{F}$
2. $30 \mu\text{F}$
3. $20 \mu\text{F}$
4. $10 \mu\text{F}$

Question Number : 120 Question Id : 2999654200 Question Type : MCQ Display Question Number : Yes Is Question Mandatory : No Single Line Question Option : No Option Orientation : Vertical

The concept of V/f control of inverters driving induction motors results in _____.

Options :

1. constant torque operation
2. speed reversal
3. reduced magnetic loss
4. harmonic elimination